

E-Tender

Two Bid Tender Document

**For
Purchase of Automatic Weather Station for Institute of Forest
Productivity, Ranchi**

[File No. Store-I-PI-AICRP: 31-54/2019-20 (III)]



Institute of Forest Productivity

Lalgutwa, NH-23 Ranchi Gumla Road, Ranchi - 835303 (Jharkhand)

CONTENT OF TENDER PAPER

This Paper includes the following Documents:

1.	Notice Inviting Tender	Chapter - I
2.	Instructions to Bidders	Chapter - II
3.	Conditions of Contract	Chapter - III
4.	Specifications and Technical details	Chapter - IV
5.	Price Schedule (To be wished by the bidders for quoting their Price)	Chapter - V
6.	Contract form	Chapter - VI



वन उत्पादकता संस्थान
भारतीय वानिकी अनुसंधान एवं शिक्षा परिषद
वन, पर्यावरण एवं जलवायु परिवर्तन मंत्रालय, भारत सरकार की एक स्वायत्त
निकाय



लालगुटवा, एन.एच-23, गुमला रोड, राँची - 835303झारखण्ड
E-mail: dir_ifp@icfre.org Phone: 0651-2526140, 2526150

No. Store-I-PI-AICRP: 31-54/2019-20 (III)

Date: 01/02/2022

निविदा आमंत्रण सूचना / NOTICE INVITING TENDER

Tenders are invited from reputed Firms/suppliers etc. For “Procurement of **Automatic Weather Station** for Institute of Forest Productivity, Ranchi Lalgutwa, NH -23 Ranchi Gumla Road, Ranchi - 835303 (Jharkhand), through the E-procurement portal at the URL <https://moefcc.euniwizarde.com>
The tender documents and other document may be downloaded from the above Portal site <https://moefcc.euniwizarde.com> and NIT of the tender will also be available at <http://ifp.icfre.gov.in> as per the schedule given in CRITICAL DATE SHEET as under. No hard copy of the tender document will be provided from the institute.

CRITICAL DATE SHEET

Published Date on website	02 nd February 2022 (11.30 AM)
Bid Submission Closing Date and Time	23 th February 2022 (05.00 PM)
Bid Opening Date and Time	24 th February 2022 (11.00 AM)

Only bidders registered on E-wizard Portal i.e. <https://moefcc.euniwizarde.com> can participate in online bidding process. Hence, the prospective bidders should ensure their registration on the E-wizard Portal. For further reference, bidders can check “Bidders Manual Kit” available in Downloads link at <https://moefcc.euniwizarde.com>

Name of Tender : Purchase of Automatic Weather Station.
Tender No. : 60/2021-22
Ref. file No. : Store-I-PI-AICRP: 31-54/2019-20 (III)
Tender Processing Fee : As per the terms of ITI Limited.
Tender Fee : Rs. 590.00 (including 18% GST)

Item No.	Items Name	EMD	Estimated Cost
I	Automatic Weather Station	Rs.30,000.00	Rs.12,00,000.00

Address of Office : Institute of Forest Productivity, P O - Lalgutwa, NH-23 Ranchi Gumla Road, Ranchi - 835303, Jharkhand.

Tender Processing Fee – As per the terms of ITI Limited.

Tender Fee, EMD etc. in the form of DD in favour of Director, Institute of Forest Productivity, Ranchi payable at Ranchi must be delivered to the Director, Institute of Forest Productivity, P O - Lalgutwa, NH-23 Ranchi Gumla Road, Ranchi - 835303, Jharkhand **on or before bid opening date/time as mentioned in critical date sheet (24th February, 2022 (11:00 AM))** Duly filled and signed tender document complete in all respect may be uploaded on the E-wizard Portal latest by **22th February, 2022 (5:00PM)** as per the critical datasheet along with all the documents mentioned in the tender form. Tenders submitted in the **hard copy will not be accepted**. Only original hard copy of Tender Fee and EMD will be accepted.

Instructions to Bidders

The bidders are required to submit the soft copies of their bids on the e-tender portal using valid Digital Signature Certificates. The instructions given below are meant to assist the bidders in registering on the e- procurement portal, prepare their bids in accordance with the requirements and submitting their bids online on the e- tender Portal.

More information useful for submitting online bids on the e-procurement portal may be obtained at <http://moefcc.euniwizarde.com>

Registration with M/s ITI Ltd. Portal (<https://moefcc.euniwizarde.com>)

Registration with M/s ITI Ltd: - Intending bidders are requested to register themselves with M/s ITI Ltd (if not registered earlier) through **<https://moefcc.euniwizarde.com>** for obtaining user-id, by paying a registration fee (2000 + GST), online tender processing fee etc. Bidders are also required to obtain **Digital Signature** for participating in the e-tender.

E-Tender Processing Fee – As per the terms of ITI Limited

For participating in the e-Tendering process, the contractor shall have to get them registered on the site **<https://moefcc.euniwizarde.com>** by making required payment through only online payment mode so that they will get user ID and Password. This will enable them to access the website, **<https://moefcc.euniwizarde.com>** with the help of Digital Signature by which they can participate in e-Tender. For this intending bidder may contact following e-Wizard Helpdesk numbers.

1. E-Wizard Helpdesk

1st floor, M-23, Road No.-25,

Near SBI Sri Krishna Nagar, Patna-800001.

Phone No.: 0612-2520545 or 9504661237, 9835871522, 9852764810, 9504486212

The intending bidder must have valid Class-III (**Signing + Encryption**) Digital Signature to submit the bid online. For this intending bidders may contact above mentioned helpdesk number.

Searching for Tender Documents:

There are various search options built in the e-procurement portal, to facilitate bidders to search active tenders by several parameters. These parameters could include Tender ID, Item/work id, Title, Date, etc.

Once the bidders have selected the tenders in which they are interested, bidder can pay non-refundable processing fee as per terms of ITI limited by net banking /Debit/ Credit Card they you may download the required documents / tender schedules, Bid documents etc. Once you pay both fee, tenders will be moved to the respective “Register” Tab. This would enable the e-procurement portal to intimate the bidders through e- mail in case there is any corrigendum issued to the tender document.

- Institute of Forest Productivity, Ranchi is a research organization under Indian Council of Forestry Research and Education, Government of India. The IFP campus is situated at Gumla Road NH-23, Lalgutwa, Ranchi. Online Tenders are invited from reputed, experienced contractors/service firms/persons, who have not been blacklisted by any government Department/Agency
- Earnest Money Deposit (EMD) and e-tender fees are to be submitted in the form of DD in favor of Director, IFP and scanned copy/soft copy of the DD receipt shall be uploaded along with the bid. Offers/Bids. Tender/Bid/Offer without e-Tender fees and the Earnest Money Deposits would not be considered and liable to be rejected.
- The contractor/firm shall have the nationality of an eligible country. A contractor/firm shall be deemed to have the nationality of a country. If it is a citizen or constituted, incorporated, or registered and operates, it will be in conformity with the provision of the laws of India. Nationality must be disclosed by the supplier.

The prices should be quoted in the following manner:

- I. The price quoted for the item of works would include the cost of materials required as per the specification specified in the said item of work as well as labour charges etc. including all excise duty and sales and other taxes already paid or payable for the said work.
- II. The Director, IFP reserves the right to reject any or all the tenders without assigning any reasons whatsoever.

Tenders/Bidders who has downloaded the tender form the <http://ifp.icfre.org> and <http://moefcc.euniwizarde.com> shall not tamper / modify the tender form including downloaded price bid template in any manner. In case if the same is found to be tampered/modified in any manner, tender will be completely rejected and EMD shall be forfeited and tenderer/bidder is liable to be banned from doing business with IFP in future. Signed and Scanned Copy of EMD must be uploaded at <http://moefcc.euniwizarde.com> and Original must be submitted and or before Closing date.

CHECKLIST

Item No.	Qualifying Documents	Yes/no	Page No.
1.	Scan Copy of Tender Fee of Rs.590/- in shape of DD in favour of Director, Institute of Forest Productivity, Ranchi payable at Ranchi		
2.	Scan Copy of EMD in shape of DD in favour of Director, Institute of Forest Productivity, Ranchi payable at Ranchi		
3.	Signed and scanned copy of PAN card		
4.	Signed and scanned copy of Tender Acceptance letter as per tender document		
5.	Signed and Scanned copy of GST certificate		
6.	Signed and scanned copy of MSME/ NSIC Registration (if exemption of tender fee and EMD is claimed)		
7.	Signed and Scanned Copy of Audited Balance Sheet of last three years		
8.	Signed and scanned copy of authorized dealership certificate		
9.	Signed and scanned copy of complete technical details/specifications of the quoted items with make and model of all systems, sub-systems and additional items mentioned in the technical bid BROUCHERS/ORIGINAL CATALOGUE with other literature and write-ups should be uploaded as proof		
10.	Signed and scanned copy affidavit in non – judicial stamp paper of Rs.10/- by the firm that it has NEVER BEEN BLACK-LISTED/DEBARRED/BANNED by any Govt. Department/Public Sector must be attached along with the bid, failing which the Bid shall be rejected.		
11.	Scanned and signed copy of Tender Document		

- Note: 1. It is compulsory to fill the above check list.
2. The document should be submitted/uploaded online in e portal in the above order of the check list and place the check list as cover page with pagination of documents.
3. In the absence of any of the above documents, the bid shall be rejected.

SIGNATURE OF THE TENDERER

Conditions of Contract

Submission of Tender

The tender shall be submitted/uploaded online in two bids viz., Technical and Price Bid

The offers submitted by Hardcopy/Fax/email shall not be considered. No correspondences will be entertained in this matter.

All the pages of the bid being submitted/uploaded must be signed and sequentially numbered by the bidder irrespective of nature of content of the documents before uploading.

Cover 1 Technical Bid:

Following documents are to be furnished by the Tenderer/Bidder along with Technical Bid as per the tender document.

Qualifying Documents:

- I. Tender Fee of Rs.590/- in shape of DD in favour of Director, Institute of Forest Productivity, Ranchi payable at Ranchi and scanned copy of the same should be uploaded in the portal. <http://moefcc.euniwizarde.com>
- II. **EMD:** Rs. 30,000/- is to be deposited in form of DD in favour of the Director, Institute of Forest Productivity, payable at Ranchi and scanned copy of the same should be uploaded in the portal. <http://moefcc.euniwizarde.com>
- III. Signed and scanned copy of PAN number
- IV. Signed and scanned copy of GST certificate , if applicable
- V. Signed and scanned copy of MSME/ NSIC Registration (if exemption of tender fee and EMD is claimed)
- VI. Signed and scanned copy of audited balance sheet of last three years.
- VII. Signed and scanned copy of authorized dealership certificate/OEM Certificate.
- VIII. Signed and scanned copy of complete technical details/specifications of the quoted items with make and model of all systems, sub-systems and additional items mentioned in the technical bid BROUCHERS/ORIGINAL CATALOGUE with other literature and write-ups should be uploaded as proof
- IX. Signed and scanned copy of affidavit in non – judicial stamp paper of Rs.10/- by the firm that it has never been black listed / debarred /banned by any Govt. Department/Public sector must be attached along with the bid, failing which the bid shall be rejected.
- X. Scanned and signed copy of tender document.
- XI. Scanned and signed copy of Tender Acceptance letter as per tender document.

Important: Earnest Money Deposit (EMD) and E- tender fees are to be submitted through DD in favour of Director, Institute of Forest Productivity payable at Ranchi in original must be Submitted on or before closing date and the scanned copy/soft copy of the same shall be uploaded along with the Tender/ Bid offers. Bids without Earnest Money Deposits would not be considered and the same would be rejected.

Cover 2: Price Bid:

Hard copies of financial bid should not be submitted physically in this institute. The financial proposal must be submitted/uploaded in the schedule of price bid in the form BOQ.xls separate of each item. Full details of business terms and conditions e.g. GST sales tax/Trade tax (whether provincial or Central), other Taxes/charges, if any, the validity period of quotation, discount , free delivery, packing or any other information relevant to the items may please be indicated clearly. **The price bid undertaking and schedule of price bid in the form of BoQ_1.xls must be filled as per format given in Chapter – V: Price Bid schedule.**

Proposal

Evaluation

Clarification of Bids

To assist in the examination, evaluation, comparison of the bids and qualification of the Bidders, the Purchaser, at its discretion, may ask any Bidder for a clarification of its Bid. The Purchaser's request for clarification and the response shall be in writing by post/email/fax etc. Any clarification submitted by a bidder in respect to its Bid and that is not in response to a request by the Purchaser shall not be considered. No change, including any voluntary increase or decrease, in the prices or substance of the bid shall be sought, offered, or permitted except to confirm the correction or arithmetic errors noticed by the Purchaser in the evaluation of the bids.

If a bidder does not provide clarifications of its bid by the date and time set in the Purchaser's request for clarification, its bid may be rejected.

Unresponsive Bids

The bids will be scrutinized to determine whether they are complete and meet the essential and important requirements, conditions etc. as prescribe in the Bid Document. The Bids are liable to be treated as non- responsive and will be rejected if bidder does not upload qualifying and technical documents as required in the bid Document.

Minor Informality/Irregularity/Non – Conformity

If during the preliminary examination, the purchaser find any minor informality and/or irregularity and /or non- conformity in a bid, the purchaser may waive the same provided it does not constitute any material deviation and financial impact and, also, does not prejudice or affect the ranking order of the bidders. Whenever necessary, the purchaser will convey its observation on such 'minor' issues to the bidder asking the bidder to respond by a specified date. If the bidder does not reply by the specified date or gives evasive reply without clarifying the point at issue in clear terms, that bid may be ignored.

A two stage procedure will be adopted in evaluating the proposals.

(i) **Technical Evaluation:**

- (a) Evaluation of Qualifying Documents: Tenders shall be scrutinized and evaluated by the Technical Committee or a Committee constituted by competent authority with reference to parameters prescribed in the Bid Document. First of all, the qualifying documents of the bid will be checked and in absence of any qualifying documents the bid will be rejected.

(ii) **Financial Evaluation:**

- (a) Financial Bids of only technically qualified bidders shall be opened online for further scrutiny and evaluation.

Terms and Conditions

1. The Director, Institute of Forest Productivity (Indian Council of Forestry Research and Education), Govt. of India, Ranchi invites e-tender under Two Bid System for Purchase of **Automatic Weather Station** from experienced and registered contractors/service firms/ persons who fulfill the minimum eligibility criteria prescribed in the e-tender document. There will be no manual submission of documents.
2. E-tender documents can be downloaded from IFP website and e – portal. Aspiring bidders/suppliers who have not enrolled/registered in e-procurement should enroll/register before participating through the website <http://moefcc.euniwizarde.com>
3. E-tender must be electronically submitted through online within prescribed data and time as mentioned in the e-procurement portal. Hard Copy of the E-tender documents will not be accepted.
4. Earnest Money Deposit (EMD) are to be submitted through DD, in favour of the Director, Institute of Forest Productivity payable at Ranchi and the scanned copy/soft copy of the same shall be uploaded along with the Technical Bid. Offers/Bids without E-Tender fees and the Earnest Money Deposit would not be considered and rejected.
5. The Bidders who are registered with the National Small Industries Corporation (NSIC) are exempted from EMD. They have to upload documentary proof along with the bid.
6. The number and quantity mentioned in the above E-tender Notice is the probable number and the same may be **increased/decreased** according to the requirement. The Director, IFP reserves the right to order or not to order any number and quantity of any instrument/equipment.
7. All the required document like technical documents, user certificate, supply order to other institutes, accreditation to quality management, PAN, TAN, GST, income tax, small scale industries exemption certificates, import license, authorization from principal supplier/manufacturer etc. along with E-Tender document should be uploaded and attached against the above E-Tender. If failed to upload and attach the E-Tender will be rejected.
8. Earnest Money Deposit (EMD):-
 - (a) The EMD to the unsuccessful e-tenderer (s) will be returned at the earliest after expiry of the final bid validity or latest on or before the 30th day of the award of the purchase order whichever is earlier.

The EMD may be forfeited if an e-Tenderer withdraws his bid during the period of bid validity specified or in case of a successful Bidder, if the bidder fails to furnish security deposit

 - i. The EMD of the unsuccessful bidder will be released after finalization.
 - ii. For the successful bidder EMD will be released after they submit the security deposit as per our instructions, otherwise
9. Technical Bid: E-tenderers shall furnish complete technical specification and duly signed failing which E-Tender will not be accepted.
10. The following scanned documents (Self attested with rubber seal, in case of photocopies) should be uploaded along with the technical bid. In case of photocopies original documents for the following should be produced whenever required; failing which E – Tender submitted will be rejected at any moment.

- a. Brochures supporting of the specifications quoted.
 - b. Authorization Certificate of the concerned company in favour of the e-tenders or the Principal dealer if the e-tenders is a sub – agent to sell/service/give annual maintenance service for the items quoted.
 - c. Document supporting both past and present status of supply of the instruments by both the Manufacturer and Supplier.
 - d. Valid proof of any orders received from various Govt./ Semi – Govt./P.S.U. etc. for supply and installation of the same make and model of scientific equipment /instruments.
11. The data of sequencing has to be delivered at this Institute.
 12. Financial Bid: The e-tenders should use Price Bid format as provided in website and rates offered should be entered in the allotted space only and submitted after filling the relevant columns. Any financial bid not given in the prescribed format will be rejected.
 - (i) The rate should be valid for a minimum of 120 days from the date of opening of the E-Tender.
 - (ii) Price list of the company if any should be uploaded along with the bid.
 13. SECURITY DEPOSIT (SD): The successful bidder/tenderer should deposit security money @ 5% of total ordered value in the form of Demand Draft within 15 days of issue of the supply order which will be refunded on completion of warranty period. Otherwise, the EMD deposited with E-Tender will be forfeited and the order placed will stand cancelled.
 - 14. ICFRE, the parent body of the IFP, Ranchi is registered with the Department of Scientific and Industrial Research (DSIR), Ministry of Science and Technology, Government of India, New Delhi for the purpose of availing customs duty exemption in terms of Government Notification No. 51/96 – Customs dated 23-7-1996, Notfn. No. 47/2017-Integrated Tax (Rate) dt. 14.11.2017 and Notfn. No. 45/2017- Central Tax (Rate) dt. 14.11.2017, and Notfn. No. 45/2017- Union Territory (Rate) dt. 14.11.2017. Therefore the parties may offer their rates without including Customs and Central excise duty.**
 15. The bids shall remain valid for 120 days after the date of bid opening. Any e-tenderers whose validity of the financial bid is for a lesser duration shall be rejected by the Institute as non-responsive.
 16. The successful e – tenderers shall be entirely responsible for all taxes, duties, license fees, octroi, road permits, etc., incurred until the service completed.
 17. The competent authority does not bind himself to accept the lowest or any other tenderer, and reserves its right to reject any or all tenders received without assigning any reasons whatsoever.
 18. The tenders, in which any of the prescribed conditions are not fulfilled or are incomplete in any respect, shall be summarily rejected.
 19. The Institute will not responsible for any delay on the part of the e-tenderers in submission of the E-tender bids. Any bids received by the Institute after the deadline prescribed for submission of bids, will be rejected.
 20. Each page of the general terms and conditions uploaded with the E-tender should be duly signed as a token of acceptance of all terms and conditions of the E-tender. No deviation in the terms and conditions of the E-tender notice will be accepted. The supporting documents should be duly stamped & signed by the e-tenders otherwise rejected. No retyping of the general terms and conditions supplied is accepted. Submit this terms and conditions duly signed along with the technical bid.
 21. The Director, Institute of Forest Productivity, Ranchi reserves the right to cancel/reject full or any part of the e-tender, without assigning any reason .No correspondence will be entertained in this regard.

22. Canvassing whether directly or indirectly, in connection with tenders is strictly prohibited and the tenders submitted by the contractors who resort to canvassing will be liable to rejection.
23. System must supply with all required accessories, and the points below:-
 - (a) The tender / proposal must include installation / commissioning and demonstration training in laboratory / field as per the standard requirement including after-sales & services.
 - (b) Minimum 1(One) year onsite warranty is required.**
 - (c) The delivery must be made at Institute of Forest Productivity, Lalgutwa Ranchi.

Specification of Automatic Weather Station (AWS)

97

Automatic weather station should be portable, light in weight, weather proof, easy to install in field, In-built rechargeable battery with following specifications:

S. No.	Item	Qty. Nos.
I. Sensors and hardware for AWS sites		
1.1	Temperature Humidity Sensor, Radiation Shield with 5m (or more, as per required length) Teflon cable and suitable MIL grade Amphenol connectors along with mounting accessories (Calibration and validity certificate of all sensors are required)	One item
1.2	Wind sensors, mounting accessories and 10 m (or more, as per required length) Teflon cable with suitable MIL grade Amphenol connectors (Calibration certificate of all sensors with validity certificate is required)	One item
1.3	Rain Gauge Sensor (Tipping Bucket Rain Gauges) with mounting accessories and with 5m (or more, as per required length) Teflon cable with suitable MIL grade Amphenol connectors (Calibration certificate of all sensors with validity certificate is required)	One item
1.4	Pressure sensors with 1m (or more, as per required length) Teflon cable (Calibration certificate of all sensors with validity certificate is required)	One item
1.5	Data logger, IP-67 compliant Enclosure with mounting accessories and USB pen drive (16 GB or more) for data retrieval	One item
1.6	Solar Radiation Sensor	One item
1.7	Soil Moisture Sensor	One item
1.8	Soil Temperature Sensor	One item
1.9	Soil Heat Flux plate-heat flux.	One item
1.10	Photosynthetically Active Radiation (PAR) Quantum Sensor	One item
1.11	Automatic Evapotranspiration Calculation logged as a Virtual Sensor	One item
1.12	General Packet Radio Service (GPRS) modem including SIM facility with minimum 8 dB antenna gain and mounting accessories	One item
1.13	Fiberglass Reinforced Polyester (FRP) Enclosures for keeping electronics items- Datalogger, Pressure sensors, solar charge controller, ON/OFF power supply switch with suitable fuses.	One item
1.14	Application software for display of data at TFT screen, Desktop PC/ Mobile Workstation /Server with license operating system software and latest version for AWS sites	One item
1.15	10 meters (as per required length) Tilttable/foldable/Sliding up and down mast for weather parameters mounting accessories	One item
1.16	Electrical charger for charging 12V,65 AH (or more) SMF BATTERY	One item
1.17	Travelling standards kits for comparison of sensors at AWS sites (Temperature-Humidity, Pressure, Rainfall and Wind speed and wind direction)	One item
1.18	12V, 65 AH (or more) SMF BATTERY with FRP Enclosures IP66	One item
1.19	40 W Solar Panel (or more) with mounting accessories on the mast with solar charge controller.	One item
1.20	Installation of 10 m (as per required length) mast and accessories, integration of data logger, sensors and other accessories, solar panel, charge controller, lightning arrestor, earthing for protection of complete AWS, fencing of field AWS site (10 m X 10 m).	One item
1.21	Hard and soft copy of operation and maintenance manuals	One item
1.22	Training of 5 or more IFP officials for at least 3 working days at the site of IFP, Ranchi.	One item

[Handwritten Signature]
11/11/2020

1/10

2	Temperature and Relative Humidity Sensor with Radiation Shield		
2.1	Air Temperature		
	a) Sensor type		Pt 100 RTD
	b) Measurement Range		-40°C to +60°C
	c) Accuracy (with radiation shield)		±0.2°C or better for +10°C to +60°C ±0.3°C or better for -40°C to +10 °C
	d) Resolution		0.1°C or better
	e) Output		Analog/ Digital
2.2	Relative Humidity		
	a) Measurement Range		0% to 100% RH
	b) Accuracy (including non-linearity, hysteresis and repeatability)		±2% RH or better with membrane filter (In the Range 10% to 100%)
	c) Output		Analog / Digital
	d) Resolution		0.05% or better
	e) Sensor type		Solid State Capacitive
2.3	Radiation Shield		
	a) Type		Thermoplastic
	b) Louvered		Minimum 9
	c) Ventilation		Natural
	d) Mounting Accessories		Aluminium Mounting bracket and Stainless-steel U Bolt clamp
2.4	Wind Sensor (Ultrasonic 2 Dimensional)		
2.4.1	Wind Speed (Anemometer)		
	a) Range (Operation)	:	0 to 60m/s or better
	b) Sustainability	:	Up to 60 m/sec
	c) Accuracy	:	±0.5 m/s or better
	d) Resolution	:	0.1 m/s
	e) Threshold	:	0.5 m/s
	f) Response time	:	1 sec or better
	g) Output	:	Digital
2.4.2	Wind Direction		
	a) Range	:	0 to 359 Degrees
	b) Accuracy	:	±5 degrees or better
	c) Resolution	:	1 deg. or better
	d) Response time	:	1 sec or better
	e) Output	:	Analog/ Digital
2.4.3	Tipping Bucket Rain Gauge sensor or with better technology		
	a) Collector Area	:	Specified Collector Area should be between 200 cm ² to 325 cm ²
	b) Height above funnel	:	Height above funnel should be sufficient to accumulate rain during heavy rainfall as per WMO guidelines.
	c) Switch	:	Rugged Magnetic Proximity
	d) Resolution	:	0.5 mm per tip
	e) Output	:	0.1 sec switch closure

Kulke
11/11/2020

	f) Accuracy	:	±2% or better, for rain rate up to 25 mm/hr ±3% or better, for rain rate between 25mm/hr to 50 mm/hr ±4% or better, for rain rate between 50mm/hr to 100 mm/hr ±5% or better, for rain rate >100 mm/hr
	g) Material of Outer Body/housing (Base/Collector)	:	Rust Proof Housing.
	h) Levelling	:	Suitable levelling adjustment screws and circular spirit level must be provided on the base of TBRG for levelling the Tipping bucket Mechanism.
	i) Debris protection filter	:	Suitable (Wire mesh) debris protection filter should be provided inside the collector.
2.5	Pressure sensor		
	a) Range	:	500 to 1100 hPa
	b) Accuracy	:	±0.2 hPa or better for complete range (500 to 1100 hPa) or better
	c) Resolution	:	0.1 or better
	d) Output	:	Digital
2.6	Solar Radiation Sensor		
	a) Range	:	0-1750 W/m ²
	b) Resolution at +20 ⁰ C	:	1 W/m ²
	c) Accuracy	:	1 W/m ² or better
2.7	Soil Moisture Sensor		
	a) Measuring Principal	:	TDR/FDR
	b) Range	:	0-100% VWC
	c) Accuracy	:	+/- 3% or better
	d) Cable	:	>3m
2.8	Soil Temperature Sensor		
	a) Range	:	-20 ⁰ C to -60 ⁰ C
	b) Resolution	:	0.1 ⁰ C
	c) Accuracy	:	+/- 0.10C or better
	d) Cable length	:	4 m
2.9	Soil Heat Flux plate-heat flux		
	a) Unit	:	Wm-2
	b) Range	:	-2000 to +2000 W/m ²
	c) Sensitivity	:	50 uv/Wm ²
	d) Accuracy	:	+/- 5% FSD or better
	e) Cable length	:	5m or more
2.10	PAR-Quantum sensor with 2m Cable		
	a) Range	:	2000m mol/m ² /sec.
	b) Resolution	:	0.01m mol/m ² /sec
	c) Accuracy	:	+/- 5% FSD or better
	d) Excitation Voltage	:	None Passive
	e) Quantum PAR Cosine Corrected	:	PAR; 400 to 700nm
	f) Cable length	:	5 Meter
2.11	Automatic Evapotranspiration Calculation logged as a Virtual Sensor.		

Handwritten signature and date: 11/11/2020

3. POWER SUPPLY

The complete AWS station shall have capability for unattended operation at remote place using Sealed Maintenance Free (SMF) battery, Electrical charger, Solar charge controller and rechargeable through a Solar panel.

- **Battery:** Single 12 V chargeable SMF battery 65 AH capacity or better.
- **The switch with fuse is required for power supply to the Data logger.**
- **Electrical charger:** There should be provision of charging the 12 V, 65 AH SMF batteries or better with 230 V AC Power supply.
- **Solar Charge controller:** It should charge the 12 V, 65 AH SMF battery or better through 40 W Solar panel and also Over-load protection, Short circuit protection, Protection from the lightning strike and Under-voltage protection.
- **Solar Panel:** Rated capacity 40 W or better, Open Circuit voltage: 21 V or better, Short circuit current: 2.5 A or better.

4. SPECIFICATIONS OF DATALOGGER, GPRS MODEM AND APPLICATION SOFTWARE FOR DISPLAY OF REAL TIME DATA

DATA LOGGER

I. General		
Datalogger quoted in tender bid should have been used for last two years in Meteorological purpose and should be well proven during severe weather conditions. Its performance certificate from users is to be submitted for last two years.		
Sl.	Features	Requirements
i)	Power	Shall Operate with 12V Power from Solar panel / Battery. Data Logger should supply controlled Power to all sensors.
ii)	Sampling	Every one second Wind, Temperature, Humidity, Pressure and every one-minute Rain Fall
iii)	Ports	<p>Sensors: Number of Ports to sample data from above sensors and redundant ports in case of failure of current ports. All Ports used to sample data should be configurable to any digital wind, temperature, pressure sensor and Rainfall available in globe. Facility to connect new sensors to redundant ports (if required). Cables from sensors are directly connected to Ports of Data Logger without any Signal conditioner in between. Having facility to apply slope and Offset for all above sensors to maintain World Meteorological Organization (WMO) accuracy. All ports are protected from surges due to lightning activities.</p> <p>RS232/USB/Ethernet Port to GPRS with SIM</p> <p>Compulsory Ethernet Port Data Output to local computer which can be configured to any Wireless Modem for communicating to Local Data Processing Computer and slave display computers (All Computers are not part of Tender). Data from Ethernet port to local computer shall be backed up every one second. The data coming out of Ethernet port shall be in the CSV text file format.</p>
iv)	Quality Checks	Before processing Data Logger shall apply quality checks such as gross error check and time consistency check for sensors be in accordance with WMO No.8 "Guide to Meteorological Instruments and Methods of Observation"

[Handwritten signature]
#1/11/2020

		Part-III Chapter 1 and Part-II Chapter 1, Seventh Edition, 2008.
v)	Key pad	Inbuilt keypad and inbuilt backlit LCD/LED display with menu driven facility to display the command, data characters. Facility to Input station parameters such as Station ID (Alphanumeric), Station name (Alphanumeric), calibration constants offset and slope of sensors etc.
vi)	Processing & Data storage	Process & Stores data one string in every minute containing one min vector average of Wind direction, speed, Temperature, Humidity, Dew point, Pressure, Mean sea level pressure, Rainfall, Max Temp, Min Temp, 24hrs Rainfall, Battery Voltage, Health status etc. Internal memory of Data Logger is sufficient to store 10 years of one minute average and one minute interval. Stored data should be transferred to a commercially available pen drive through a front panel key. It shall compute & store Daily minimum Temperature at 03UTC, Daily maximum at 12UTC, 24 Hrs Rainfall at 03 UTC.
vii)	RTC	RTC clock should have internal battery for retention of time in absence of External Power supply. Stability Long-term is 1 ppm/year or better.
viii)	Communication to GPRS	GPRS Modem should be external to Data Logger. Stored data every 1min should be communicated via GPRS Modem with single/dual SIM to Central Server. If Data logger unable to send data through GPRS modem for some due to absence of mobile data connectivity the all logged data to be communicated to central server as & when communication link established. Provision to access Data logger from remote for retrieval of data or any purpose with password protection. GPRS Modem in built in the Data Logger is also acceptable provided SIM card slot is external.
ix)	Software	Interface. Software in data Logger is upgradable by transferring
		upgraded software to Data logger through USB Pen drive

5. GPRS Modem with SIM Facility

GPRS Modem with SIM facility and also have provision of fast and reliable wireless data communications along with support for IP based access to the central server IP. The following technical specifications are indicative.

Handwritten signature and date: 11/11/2020

- a) Operating on standard SIM card.
- b) Suitable High gain GPRS Antenna for reliable communication and to connect to nearest mobile tower.
- c) Operate with 12V DC Power supply.
- d) Provision to configure to SIM Cards used and IP address and Port no of central Data receiving server.
- e) GPRS facility with fast and reliable wireless data communications.
- f) Remote dial-up facility.
- g) Shall support SMS, Email , FTP and TC/IP.
- h) Ethernet/RS 232/RS 485/USB interface with Datalogger.
- i) Indication of network availability (signal strength).

6. Application software for Display of Real time data

Application Software required for local display on a computer monitor should work on windows-based PC and application software should be up gradable without any cost on purchaser with new windows version.

7. WEATHER PROOF FRP ENCLOSURE FOR AWS

- a. Two separate enclosures are required for AWS.
- b. Weather proof Enclosure of AWS should be FRP Enclosure (IP 66) and for outdoor use to provide a degree of protection against falling dirt, rain, sleet, snow, windblown dust, splashing water, and hose-directed water.
- c. **One enclosure** FRP Enclosure (IP 66) is suitable to keep Data logger, solar charge Controller, Pressure sensors, switch with suitable fuse for power supply to Data logger and GPRS modem
- d. **Another separate** FRP Enclosure (IP 66) for 12 V, 65 AH SMF batteries.
- e. Silicone gasket is used for both Enclosures for harsh environments and extreme temperatures.
- f. FRP Enclosure (IP 66) enclosures should be designed for outdoor applications that require corrosion protection against chemicals and water. From humble to harsh environments, it safeguards vital electrical and electronic components with enclosures, climate control and accessories to help keep operations up and running smoothly.
- g. Enclosure with hinged door and locking facility.
- h. Data Pockets provide convenient storage for wiring diagrams, operation manuals and other documentation inside an enclosure.

8. MAST FOR AWS (Tiltable type / Foldable/Sliding up and down)

- i. Mast shall be 10-meter (Tiltable type / Foldable/Sliding up and down) mast. The mast is designed to withstand high wind conditions, up to 60 m/s of maximum wind speed, with a standard set of guy wires.
- j. It shall be corrosion resistant and salt water resistant.
- k. The Mast can be lowered down any time to remove for maintenance and reinstallation of the wind sensors.
- l. Instrument booms suitable for mounting on the Mast need to be designed on the basis of the mounting requirements of the sensors.
- m. The bidder shall be responsible for installation of sensors at various levels, fixing and laying of the signal cables from all the sensors up to the ground level along with fixing the cable identification tags. The signal cables should be laid out properly on the mast and tied to the structure elements with cable ties of appropriate lengths.
- n. Tension in the guy wires shall be adjusted by means of tension meters or any standard method for adjusting the tension in the guy wires may be followed and tension should be adjusted in the presence of IMD official.

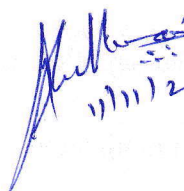
11/11/2020

o. The overall specifications of Mast are given in table below:

94

1.	Height	10 m
2.	Wind sustainability	60 m/s
3.	Guy levels	At 6 m
4.	Lightning Arrestor	A lightning arrestor with spiked copper rod of at least 10 meter height should be installed at the top of the mast and connected to an earth pit with copper bars and suitable copper cable. Separate maintenance free type earth pit conforming to the relevant IS specifications should be provided for this purpose.
5.	Cable routing	Provision for cable routing from instrument booms / junction boxes to the bottom of the mast will be provided. The cable bunch has to run in a flexible PVC pipe / with equivalent arrangement from top to the lower end of the tower and into the instrument enclosure

System must be supplied with all above sensor, solar panel, mast/tripod, Data Handling system and any other components/parts for proper and efficient functioning along with all the required accessories of all components and sub components, and the points below:

- a. The tender/proposal must include installation/commissioning and demonstration training in laboratory/field as per the standard requirement including after-sales & services, and as mentioned earlier in the document. After sales service must be extended as and when required.
- b. Minimum 3 (Three) years or more onsite warranty is required.
- c. The items must be supplied at Institute of Forest Productivity, Aranyodaya, NH-23, Kathal More, Lalgutwa, Ranchi – 835303, and installation will be done at the site prescribed by the institute including onsite training.

11/11/2020

7/10

INDICATIVE SCHEMATIC VIEW OF AWS SITE

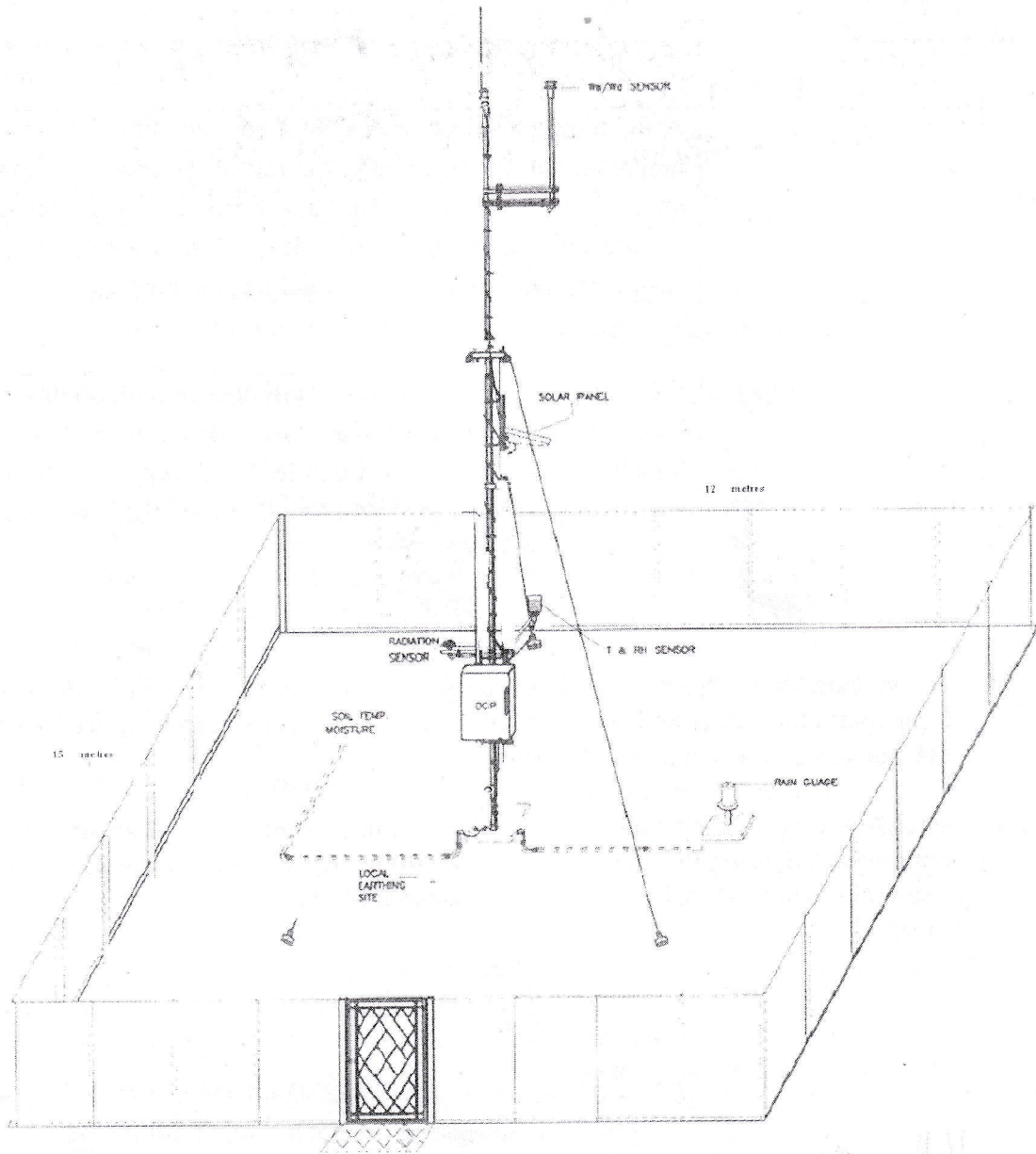

Handwritten signature and date:
11/11/2020

Calibration

No	Feature	Requirement
a)	Calibration traceability	The calibration of the barometer, Relative Humidity and Temperature, wind speed and rainfall shall be traceable to NIST or any other World recognized Institute.
b)	Post calibration of the kit through secondary standard.	<ul style="list-style-type: none"> The travelling standards after the use in the field need to be recalibrated/ checked and adjusted with secondary standards available in IFP. The supplied equipment shall have facility to recalibrate them and add/ store the adjustments, if required. The pressure sensor shall have the capability for Linear and multi-point adjustments whereas temperature and humidity sensor shall have the facility for linear adjustments. The successful bidder needs to demonstrate the calibration procedure during the acceptance of the equipment. The calibration procedure complying with the above requirement shall be submitted along with the technical bid. This is a mandatory requirement for the calibration kit.

Display Requirements: The equipment display / displays should provide the following facilities

No	Feature	Description
a)	Display	LCD with backlit display with graphic trend display of parameters Quantities and units. Graphic history.
b)	Function	Alarm. Digital/Analog output display
c)	Recording / Viewing	Record data. View recorded data. Memory status. Clear data memory. Date and time.
d)	Ports	Shall have ports to interface Atmospheric Pressure sensor, Air
e)	Power	Rechargeable battery pack with AC adapter. The power to the sensors shall be provided through display unit.
f)	Data interface	Atmospheric Pressure sensor: RS232 Air Temperature and Relative Humidity Sensor: RS485

[Handwritten signature]
11/11/2020

Basic Block Diagram of Field site AWS and its Communication

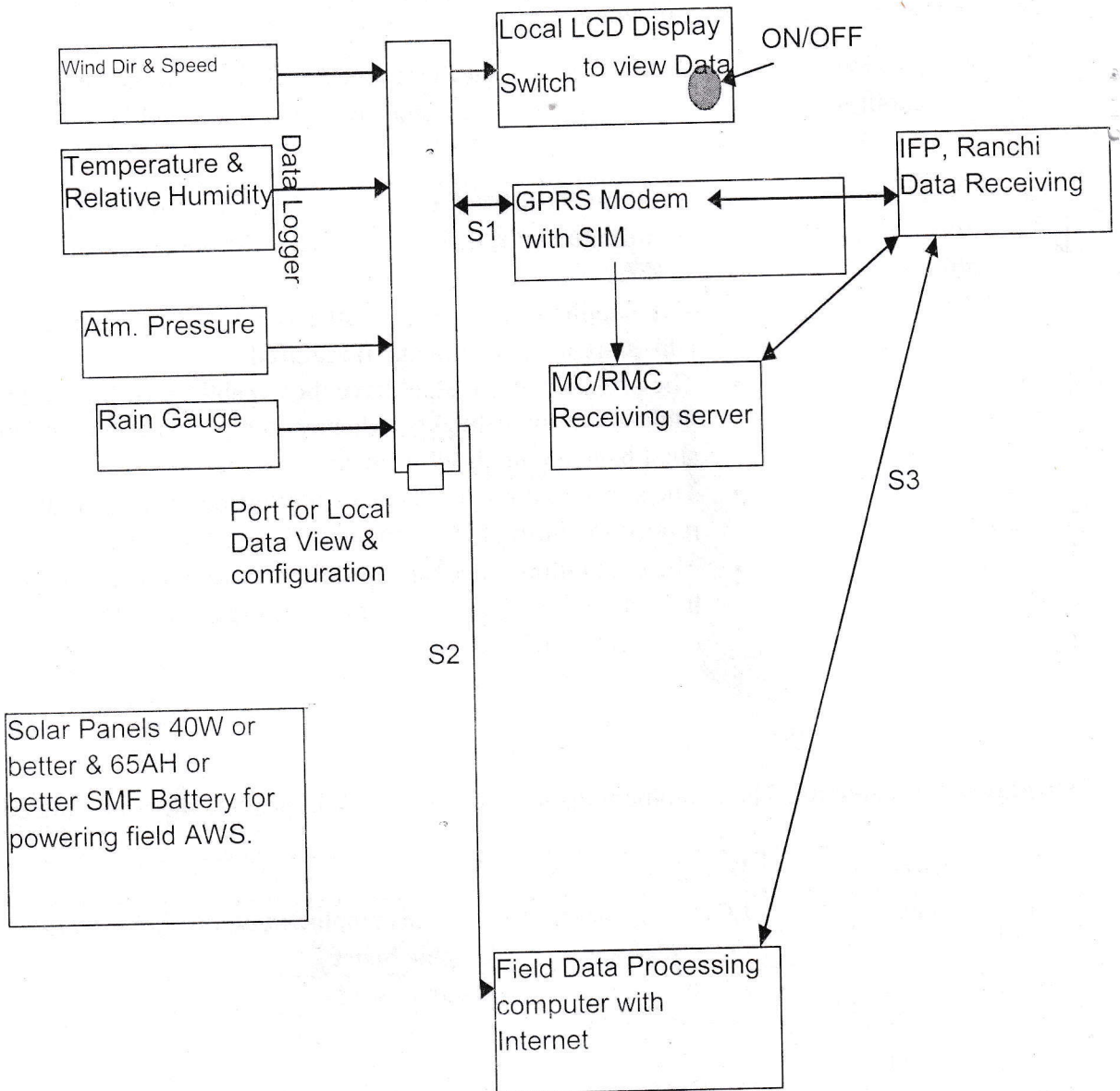

Handwritten signature and date: 11/11/2020

Price Schedule

(a) Price bid undertaking : The format of Price bid undertaking as given under:

From (Full Name and address of the Bidder)

To

The Director

Institute of Forest Productivity, Ranchi

Dear Sir/Madam,

I submit the price Bid for _____ and related activities as envisaged in the Bid Document.

I have thoroughly examined and understood all the terms and conditions as conditions as contained in the Bid document, and agree to abide by them.

I offer to work supply the quoted item at the rates as indicated in the price Bid inclusive of all applicable taxes.

Signature of authorized Representative

(b) Schedule of Price Bid in the form of BoQ_1.xls

The prices should be quoted only in BoQ_1.xls available in the e-portal.

The below mentioned Financial/Proposal/Commercial Bid format is provided as BoQ_1.xls along with his bid document at <http://moefcc.euniwizarde.com> bidders are advised to download at this BoQ_1.xls as it is the quote their offer/rates in the permitted column and upload the same in the commercial bid. Bidder shall not tamper/modify downloaded price bid template in any manner. In case if the same is found to be tampered/modified in any manner, tender will be completely rejected and EMD would be forfeited and bidder is liable to be banned from doing business with IFP

1. The rates, taxes, charges, etc. should be quoted as per BoQ.
2. All taxes , fees, leives, etc. and any revision in the statutory taxes/fees, etc will be the responsibility of the bidder.
3. In case of any discrepancy / difference in the amounts indicated in figures and words the amounts in words will prevail and will be considered.
4. The quoted rates shall remain firm throughout the tenure of the contract and no revision is permissible for any reason.

Authorized Signatory

(Signature of the Authorized Person)

Agreement/Contract Form Tender Acceptance Letter

(To be given on company Letter Head)

Date.....

To

The Director,
Institute of Forest Productivity, Ranchi.

Sub: Acceptance of Terms and Conditions of Tender.

Tender Reference No.:

Name of the :

Tender/Work:

Dear Sir,

1. I/We have downloaded/obtained the tender document(s) for the above mentioned 'Tender/Work' from the web site(s) name _____
____As per your advertisement, given in the above mentioned website(S).
2. I/We hereby certify that I/we have read the entire terms and conditions of the tender documents from Page No. _____To__ (including all documents like annexure(s), schedule (s) etc.,) which form part of the contract agreement and I/we shall abide hereby by the terms /conditions/clauses contained therein.
3. The corrigendum(s) issued from time to time by your department/organization too have also been taken into consideration, while submitting this acceptance letter.
4. I/we hereby unconditionally accept the tender conditions of above mentioned tender document(s)/corrigendum(s) in its totality/entirely.
5. I/we do hereby declare that one firm has not been blacklisted/debarred/banned by any Govt. Department / Public sector undertaking.
6. I/we certify that all information furnished by the our firm is true & correct and in the event that the information is found to be incorrect/untrue or found violated, then your department/organization shall without giving any notice or reason therefore or summarily reject the bid or terminate the contract without prejudice to any other rights or remedy including the forfeiture of the full said earnest money deposit absolutely.

Yours faithfully

(Signature of the Bidder, with Official Seal)